



AIC1653

Micropower Inverting DC/DC Converter in SOT-23-5

FEATURES

- Low Quiescent Current:
 - 15 μ A in Active Mode
 - <1 μ A in Shutdown Mode
- Operates with VIN as Low as 1.8V
- Uses Small Surface Mount Components
- High Output Voltage: Up to -28V
- Low profile 5-Lead SOT-23-5 Package

APPLICATIONS

- LCD Bias
- Hand-Held Computers
- Battery Backup
- Digital Still Cameras

DESCRIPTION

The AIC1653 is a micropower inverting DC/DC converter in 5-lead SOT-23 package. It is designed for power systems with a 100mA current limit and an input voltage ranging from 1.8V to 10V. Besides, AIC1653 features a quiescent current of only 15 μ A at no load, which further reduces to 0.5 μ A when shutdown. The schemes of current limited and fixed off-time control conserve operating current, resulting in high efficiency over a broad range of load current. In addition, the 30V switch of AIC1653 allows high voltage outputs up to -28V, which is easily generated without the use of costly transformers. The AIC1653's low off-time of 400ns permits the use of tiny, low profile inductors and capacitors to minimize footprint and cost in space-conscious portable applications.

TYPICAL APPLICATION CIRCUIT

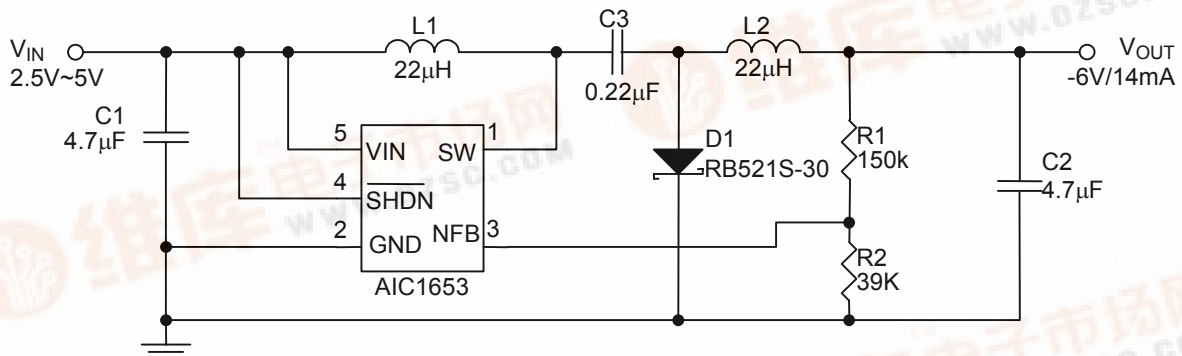

L1,L2: TOKO D312F 22 μ H
 D1: Rohm RB521S-30
 C1,C2,C3: TAIYO YUDEN Ceramic capacitors



ORDERING INFORMATION

AIC1653CXXX

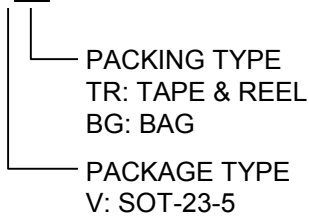

Example: AIC1653CVTR
 → in SOT-23-5 Package & Tape & Reel
 Packing Type

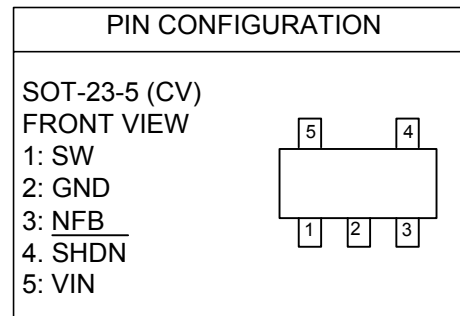

● **SOT-23-5 Marking**

Part No.	Marking
AIC1653	1653

ABSOLUTE MAXIMUM RATINGS (Note 1)

VIN, SHDN Voltage.....	10V
SW Voltage.....	30V
NFB Voltage.....	-3V
Junction Temperature.....	125°C
Operating Temperature Range (Note 2).....	-40°C to 85°C
Storage Temperature Range.....	-65°C to 150°C
Lead Temperature (Soldering, 10 sec).....	300°C

TEST CIRCUIT

Refer to Typical Application Circuit.

■ **ELECTRICAL CHARACTERISTICS** ($T_A = 25^\circ\text{C}$, $V_{IN} = 3.6\text{V}$, $V_{\overline{\text{SHDN}}} = 3.6\text{V}$ unless otherwise specified)

PARAMETER	TEST CONDITIONS	MIN.	TYP.	MAX.	UNIT
Minimum Input Voltage				1.8	V
Quiescent Current	Not Switching		15	20	μA
	$V_{\overline{\text{SHDN}}} = 0\text{V}$			1	
FB Comparator Trip Point		-1.205	-1.23	-1.255	V
FB Comparator Hysteresis			10		mV
Output Voltage Line Regulation (Note 3)	Refer to Fig.7		0.05		%/V
FB Pin Bias Current (Note 4)	$V_{\text{NFB}} = -1.23\text{V}$	1.3	2	2.7	μA
Switch Off Time	$\text{NFB} \leq -1\text{V}$		400		nS
	$\text{NFB} \geq -0.6\text{V}$		800		nS
Inter Switch On-Resistance		0.6	1	1.4	Ω
Switch Current Limit		75	100	125	mA
$\overline{\text{SHDN}}$ Input Voltage High		0.9			V
$\overline{\text{SHDN}}$ Input Voltage Low				0.25	V
Switch Leakage Current	Switch Off, $V_{\text{SW}} = 5\text{V}$		0.01	5	μA

Note 1: Absolute Maximum Ratings are those values beyond which the life of a device may be impaired.

Note 2: Specifications over the -40°C to 85°C operating temperature range are assured by design, characterization and correlation with statistical process controls.

Note 3: Output voltage line regulation is guaranteed by design, characterization and correlation with statistical quality controls, not production tested.

Note 4: Bias current flows out of the NFB pin.

TYPICAL PERFORMANCE CHARACTERISTICS

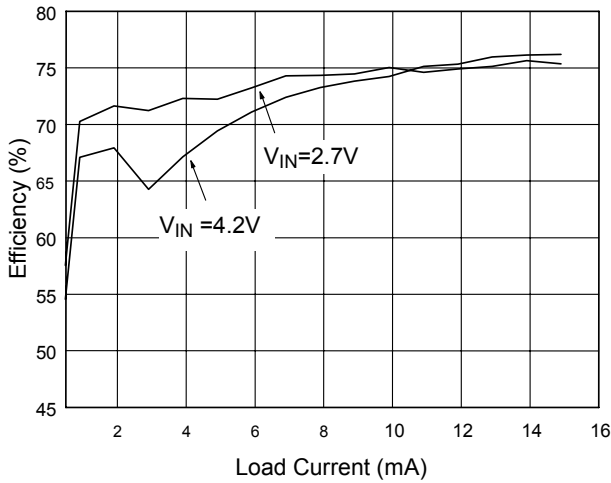

Fig. 1 Load Current vs. Efficiency
(Refer to typical application circuit)

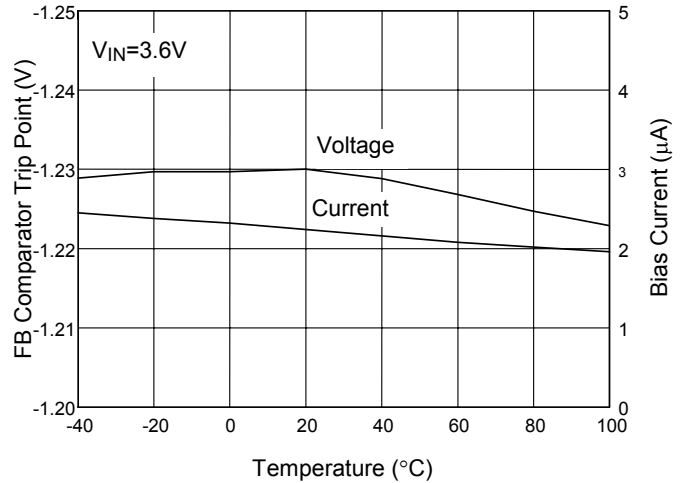

Fig. 2 FB Comparator Trip Point and Pin Bias Current vs. Temperature

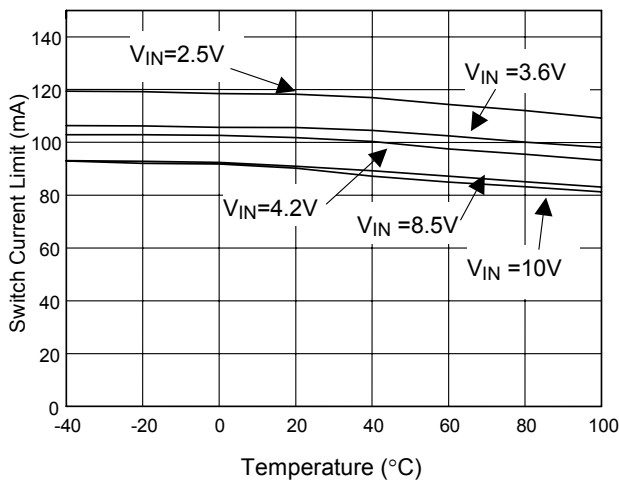

Fig. 3 Switch Current Limit vs. Temperature

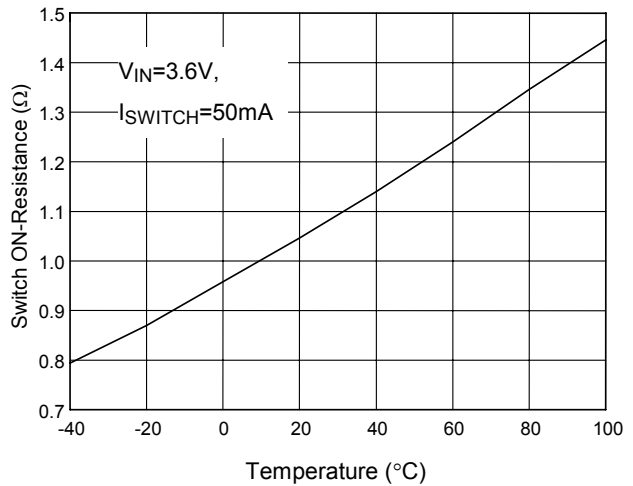

Fig. 4 Switch ON-Resistance vs. Temperature

TYPICAL PERFORMANCE CHARACTERISTICS (Continued)

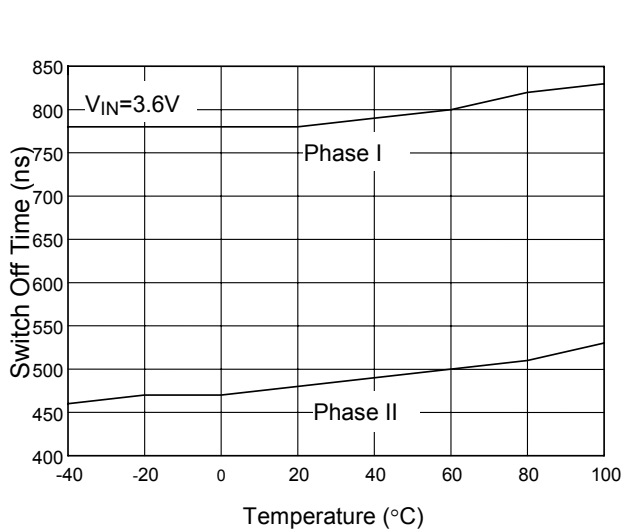

Fig. 5 Switch Off Time vs. Temperature

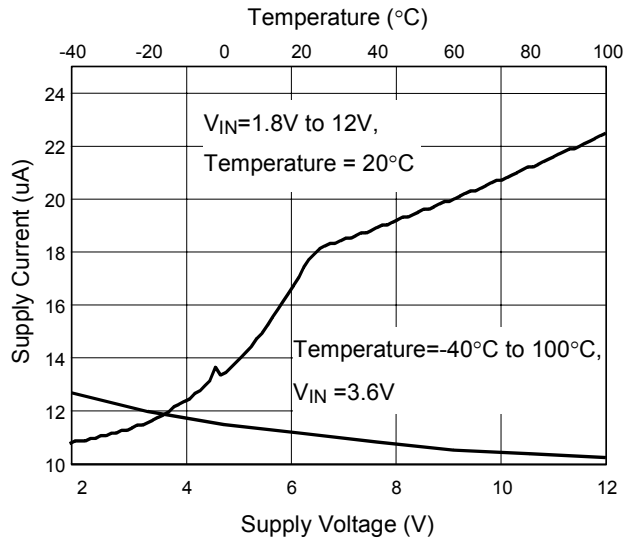

Fig. 6 Quiescent Current vs. Temperature and Voltage

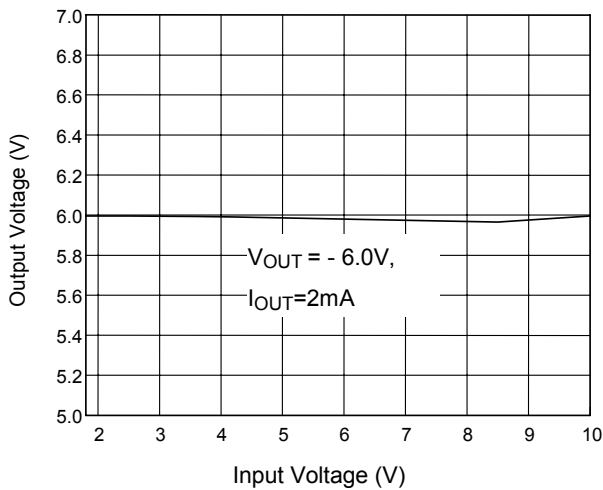

Fig. 7 Line Regulation

■ BLOCK DIAGRAM

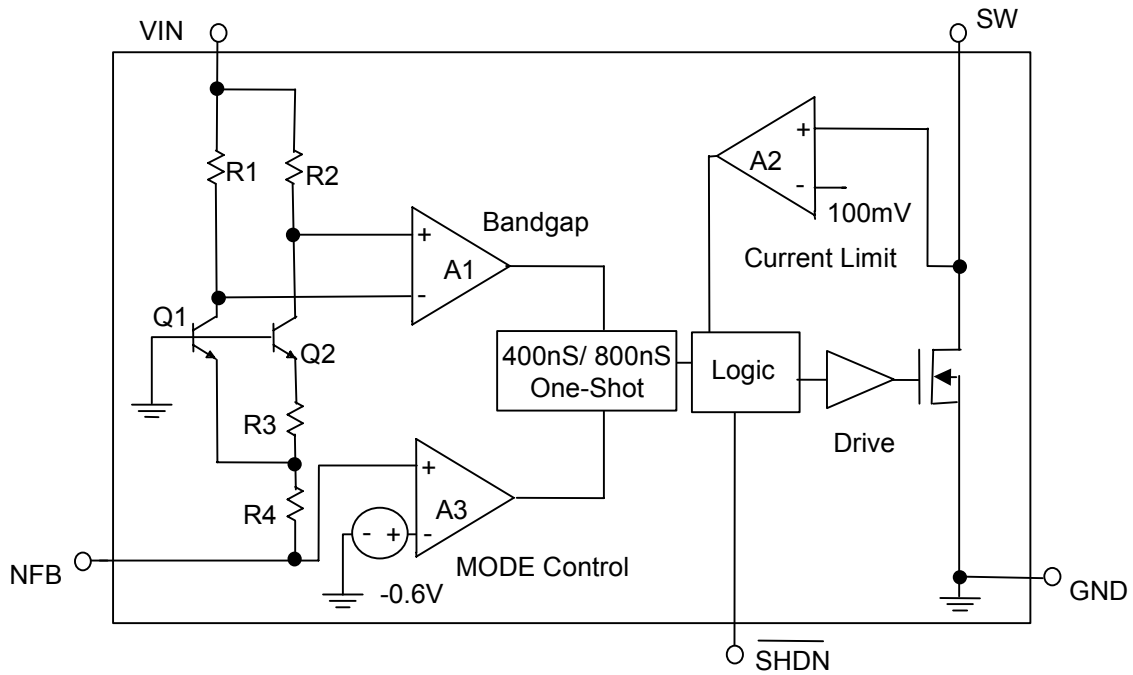

Fig. 8 Block diagram of AIC1653

■ PIN DESCRIPTIONS

- PIN 1: SW** - Switch Pin. This is the open drain of the internal N-MOSFET power switch. Minimize the metal trace area connected to this pin to minimize EMI.
- PIN 2: GND** - Ground. Tie this pin directly to the local ground plane.
- PIN 3: FB** - Set the output voltage by values of R1 and R2 (see typical application circuit):

$$R1 = \frac{|V_{OUT}| - 1.23}{\frac{1.23}{R2} + (2 \times 10^{-6})}$$

- PIN 4: SHDN** - Shutdown Pin. Tie this pin to 0.9V or higher to enable the device. Tie below 0.25V to turn off the device.
- PIN 5: VIN** - Input Supply Pin. Bypass this pin with a capacitor as close to the device as possible.

APPLICATION INFORMATIONS

Principle of Operation

AIC1653 uses a constant off-time control scheme, which is represented in Fig. 8, to provide high efficiency over a range of output current. Q1 and Q2 along with R3 and R4 form a bandgap reference used to regulate the output voltage. When the voltage at NFB pin is slightly below -1.23V, comparator A1 disables most of the internal circuitry. Output current is then provided by output capacitor, which slowly discharges until the voltage at the NFB pin goes above the hysteresis point of A1. A1 then enables the internal circuitry to turn power switch NMOS on, and the current in inductor begins ramping up. Once the switch current reaches 100mA, comparator A2 resets one-shot, which turns NMOS off for 400ns. In the meantime, the inductor continues to deliver current to the output. When NMOS turns back on, the inductor current ramps up. And A2 resets one-shot again when switch current gets to 100mA. This switching action continues until the output voltage is charged up with NFB pin reaching -1.23V. Then A1 turns the internal circuitry off and the cycle repeats. The AIC1653 contains additional circuitry to provide current-limit protection for start-up as well as short-circuit protection. When FB pin voltage is higher than -0.6V, switch off-time is increased to 800nS. This reduces the average inductor current and helps minimize the power dissipation in AIC1653 power switch, and in the external inductor and diode.

Component Selection

Inductor Selection – Inverting Regulator

The following formula calculates the appropriate inductor value for an inverting regulator. This value provides a good tradeoff in inductor size and system performance. In any applications, the closest value to the one from the formula needs to be applied to the inductors (both inductors should have the same value). A use of an inductor value up to 22μH can induce a slight increase of output current, but any value beyond that will result in high output ripple voltage with no further output current increase. The size of inductor can be reduced by using a value under 22μH. The formula is shown as below:

$$L = 2 \left(\frac{|V_{OUT}| + V_D}{I_{LIM}} \right) \times t_{OFF} \quad (1)$$

where $V_D=0.4V$ (Schottky diode forward voltage), $I_{LIM}=100mA$, and $t_{OFF}=400nS$.

Be aware that, based on formula (1), high output voltage can raise inductance, which may cause an increase of inductor size.

For a converter (typical application circuit) converting from 3.6V to -6V, a 51.2μH inductor is calculated from the above equation. However, a 22μH inductor is recommended instead to prevent the loss of output current.

Inductor Selection – Inverting Charge Pump Regulator

This topology, inverting charge pump regulator, is recommended when internal power switch voltage is over its maximum rating.

As the inverting regulator application above, its internal power switch voltage is 9.6V (the sum of the absolute value of 3.6V input and -6V output), which is fine as it is under the maximum rating, 30V. However, any applications of internal power switch voltage exceeding the maximum rating, topology of inverting charge pump regulator is recommended for their system.

For example, a 12V to -30V converter will generate 42V internal power switch voltage, which exceeds its maximum rating 30V. For such a system, an inverting charge pump regulator is the recommended topology.

Appropriate inductor value for an inverting charge pump regulator can be calculated by formula (2). For designs with varying V_{IN} value such as battery-powered applications, minimum V_{IN} value is used in formula (2).

$$L = \frac{|V_{OUT}| - V_{IN(MIN)} + V_D}{I_{LIM}} t_{OFF} \quad (2)$$

Capacitor Selection

Output Capacitors

Low ESR (Equivalent Series Resistance) capacitors should be used at output terminal to minimize the output ripple voltage.

Multilayer ceramic capacitors are the best choice as they have a very low ESR and are available in low-profile packages. Due to the advantage of small size, it makes multilayer ceramic capacitors and AIC1653's SOT-23 packages good companions for size-concerning applications.

Solid tantalum capacitors are another alternative for output capacitors, but they take more board area and have larger ESR than ceramics.

Input Capacitors

Ceramic capacitors also make a good choice for the input decoupling capacitor, which should be placed as close as possible to AIC1653. A 4.7 μ F input capacitor is sufficient for most applications.

Be aware that, sufficient voltage rating is required for capacitor selection.

Diode Selection

For most AIC1653 applications, Rohm RB521S-30 surface mount Schottky diode (200mA, 30V) providing the advantage of low forward voltage and fast switching speed is an ideal choice. Note that, generally, rating of handling minimum current at 1A is required for AIC1653 applications.

Reducing Output Ripple Voltage

Using low ESR capacitors will help reduce the output ripple voltage. In addition, proper selection of the inductor and the output capacitor plays an important role in output ripple voltage reduction.

The AIC1653 provides energy to the output in

bursts by ramping up the inductor current, which is then delivered to load. If either inductor value over 22μH or capacitor value under 4.7μF is used, output ripple voltage will increase because the capacitor will be slightly overcharged in each burst cycle. Two methods of helping reduce output ripple voltage are recommended. One is to increase the output capacitor value. Adding a 100pF feedforward capacitor that is parallel with R1 (see Fig.13) is the other. And the addition of the small capacitor will greatly reduce output ripple voltage.

Output Voltage Programming

A resistive divider, as in formula (3), sets the output voltage.

$$V_{OUT} = -\left(1.23V\left(1 + \frac{R1}{R2}\right) + R1 \times \left(2 \times 10^{-6}\right)\right) \quad (3)$$

A capacitor at 100pF in parallel to the upper feedback resistor is required for a stable feedback.

PCB Layout

Proper PCB layout and component placement may enhance the performance of AIC1653 application circuit. For a better efficiency, major loop from input terminal to output terminal should be as short as possible. In addition, in a case of a large current loop, the track width of each component in the loop should maintain as wide as possible. In order to get rid of noise interference, separation of Schottky diode ground and output terminal ground into two independent parts is required. Recommended layout diagrams and component placement are shown as Fig. 9 to Fig. 12.

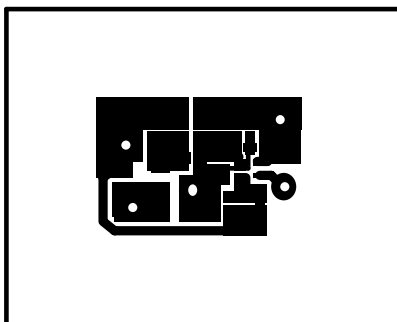

Fig. 9 Top Layer

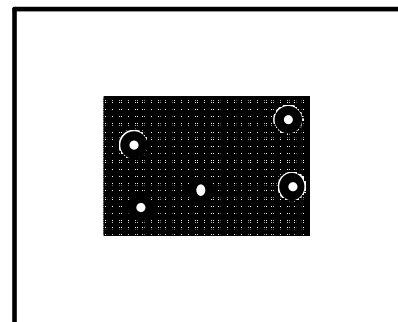

Fig. 10 Bottom Layer

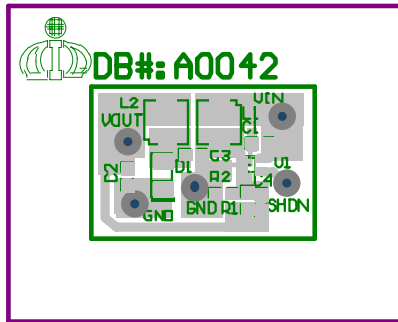

Fig. 11 Top Placement

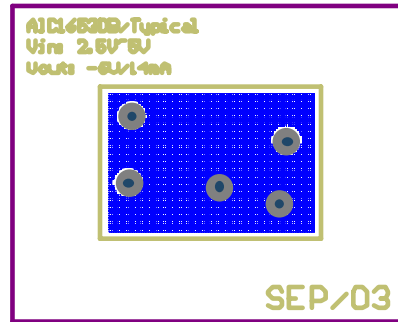
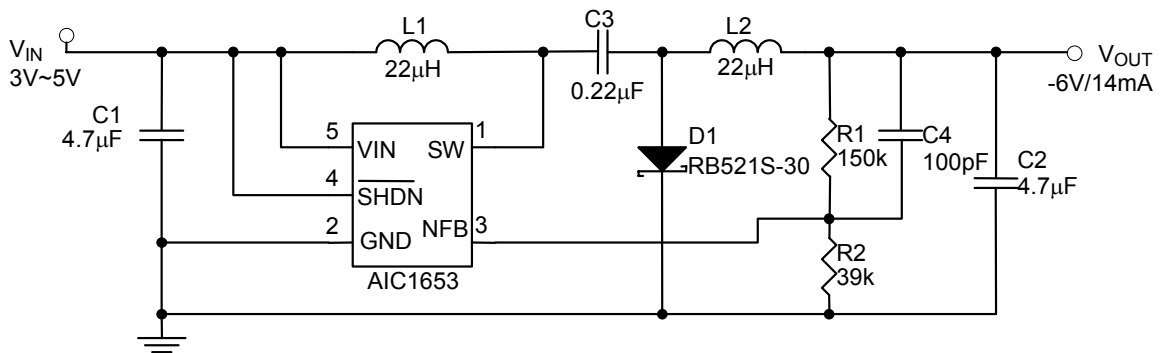

Fig. 12 Bottom Placement

APPLICATION EXAMPLES



L1,L2: TOKO D312F 22µH
 D1: Rohm RB521S-30
 C1,C2,C3: TAIYO YUDEN Ceramic capacitors

Fig. 13 OLED Application for Single Li-Ion Input

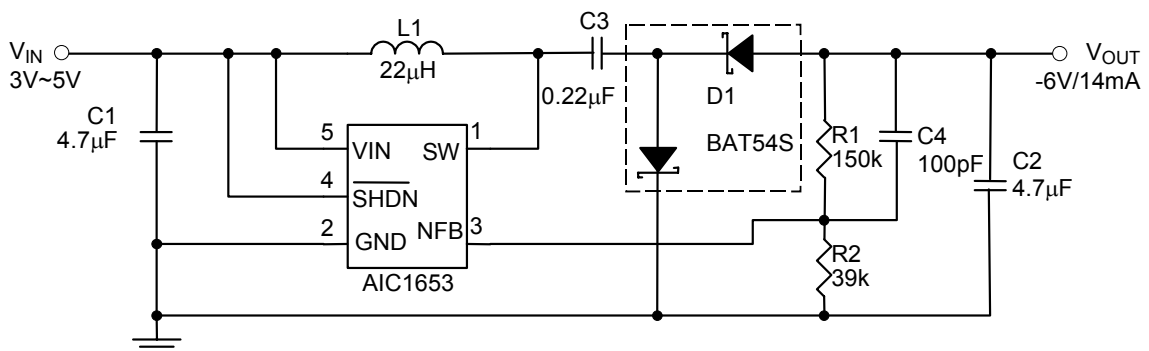

L1: TOKO D312F 22µH
 D1: CHENMKO BAT54S
 C1,C2,C3: TAIYO YUDEN Ceramic capacitors

Fig. 14 Inverting Charge Pump Application

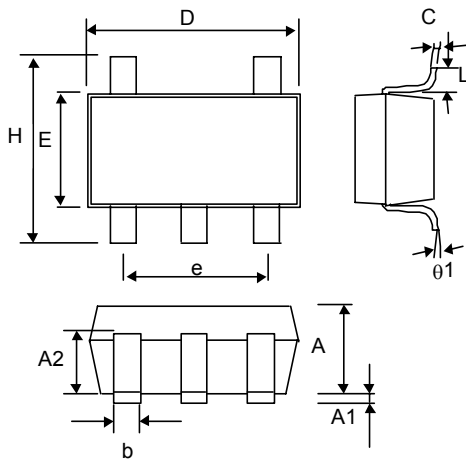
PHYSICAL DIMENSIONS (unit: mm)
SOT-23-5 (CV)

SYMBOL	MIN	MAX
A	1.00	1.30
A1	—	0.10
A2	0.70	0.90
b	0.35	0.50
C	0.10	0.25
D	2.70	3.10
E	1.40	1.80
e	1.90 (TYP)	
H	2.60	3.00
L	0.37	—
θ1	1°	9°

Note:

Information provided by AIC is believed to be accurate and reliable. However, we cannot assume responsibility for use of any circuitry other than circuitry entirely embodied in an AIC product; nor for any infringement of patents or other rights of third parties that may result from its use. We reserve the right to change the circuitry and specifications without notice.

Life Support Policy: AIC does not authorize any AIC product for use in life support devices and/or systems. Life support devices or systems are devices or systems which, (i) are intended for surgical implant into the body or (ii) support or sustain life, and whose failure to perform, when properly used in accordance with instructions for use provided in the labeling, can be reasonably expected to result in a significant injury to the user.