

APT1001RBNR 1000V 11.0A 1.00Ω
 APT1001R1BNR 1000V 10.5A 1.10Ω

POWER MOS IV®

UIS RATED

N-CHANNEL ENHANCEMENT MODE HIGH VOLTAGE POWER MOSFETS

MAXIMUM RATINGS

All Ratings: $T_C = 25^\circ\text{C}$ unless otherwise specified.

Symbol	Parameter	APT1001RBNR	APT1001R1BNR	UNIT
V_{DSS}	Drain-Source Voltage	1000	1000	Volts
I_D	Continuous Drain Current @ $T_C = 25^\circ\text{C}$	11	10.5	Amps
I_{DM}	Pulsed Drain Current ⁽¹⁾	44	42	
V_{GS}	Gate-Source Voltage Continuous	±20		Volts
V_{GSV}	Gate-Source Voltage Transient	±30		
P_D	Total Power Dissipation @ $T_C = 25^\circ\text{C}$	310		Watts
	Linear Derating Factor	2.5		W/°C
T_J, T_{STG}	Operating and Storage Junction Temperature Range	-55 to 150		°C
T_L	Lead Temperature: 0.063" from Case for 10 Sec.	300		
I_{AS}	Avalanche Current ⁽¹⁾ (Repetitive and Non-Repetitive)	11		Amps
E_{AR}	Repetitive Avalanche Energy ⁽¹⁾	25		mJ
E_{AS}	Single Pulse Avalanche Energy ⁽⁴⁾	1210		

STATIC ELECTRICAL CHARACTERISTICS

Symbol	Characteristic / Test Conditions	MIN	TYP	MAX	UNIT
BV_{DSS}	Drain-Source Breakdown Voltage ($V_{GS} = 0V, I_D = 250 \mu\text{A}$)	1000			Volts
$I_D(\text{ON})$	On State Drain Current ⁽²⁾ ($V_{DS} > I_D(\text{ON}) \times R_{DS}(\text{ON}) \text{ Max}, V_{GS} = 10V$)	APT1001RBNR	11		Amps
		APT1001R1BNR	10.5		
$R_{DS}(\text{ON})$	Drain-Source On-State Resistance ⁽²⁾ ($V_{GS} = 10V, 0.5 I_D(\text{Cont.})$)	APT1001RBNR		1.00	Ohms
		APT1001R1BNR		1.10	
I_{DSS}	Zero Gate Voltage Drain Current ($V_{DS} = V_{DSS}, V_{GS} = 0V$)			250	μA
	Zero Gate Voltage Drain Current ($V_{DS} = 0.8 V_{DSS}, V_{GS} = 0V, T_C = 125^\circ\text{C}$)			1000	
I_{GSS}	Gate-Source Leakage Current ($V_{GS} = \pm 20V, V_{DS} = 0V$)			±100	nA
$V_{GS}(\text{TH})$	Gate Threshold Voltage ($V_{DS} = V_{GS}, I_D = 1.0\text{mA}$)	2		4	Volts

THERMAL CHARACTERISTICS

Symbol	Characteristic	MIN	TYP	MAX	UNIT
$R_{\theta JC}$	Junction to Case			0.40	°C/W
$R_{\theta JA}$	Junction to Ambient			40	

CAUTION: These Devices are Sensitive to Electrostatic Discharge. Proper Handling Procedures Should Be Followed.

405 S.W. COLUMBIA STREET
 BEND, OREGON 97702-1035
 U.S.A.

PHONE . . . (503) 382-8028

FAX (503) 388-0364

DYNAMIC CHARACTERISTICS

APT1001R/1001R1BNR

Symbol	Characteristic	Test Conditions	MIN	TYP	MAX	UNIT
C_{iss}	Input Capacitance	$V_{GS} = 0V$ $V_{DS} = 25V$ $f = 1 MHz$		3400	4000	pF
C_{oss}	Output Capacitance			330	500	
C_{rss}	Reverse Transfer Capacitance			126	190	
Q_g	Total Gate Charge ③	$V_{GS} = 10V$ $V_{DD} = 0.5 V_{DSS}$ $I_D = I_D [Cont.] @ 25^\circ C$		150	210	nC
Q_{gs}	Gate-Source Charge			16	25	
Q_{gd}	Gate-Drain ("Miller") Charge			75	110	
$t_d(on)$	Turn-on Delay Time	$V_{GS} = 15V$ $V_{DD} = 0.5 V_{DSS}$ $I_D = I_D [Cont.] @ 25^\circ C$ $R_G = 1.8\Omega$		18	36	ns
t_r	Rise Time			22	45	
$t_d(off)$	Turn-off Delay Time			110	160	
t_f^*	Fall Time			42	85	

SOURCE-DRAIN DIODE RATINGS AND CHARACTERISTICS

Symbol	Characteristic / Test Conditions	MIN	TYP	MAX	UNIT
I_S	Continuous Source Current (Body Diode)	APT1001RBNR		11	Amps
		APT1001R1BNR		10.5	
I_{SM}	Pulsed Source Current ① (Body Diode)	APT1001RBNR		44	Amps
		APT1001R1BNR		42	
V_{SD}	Diode Forward Voltage ② ($V_{GS} = 0V, I_S = -I_D [Cont.]$)			1.3	Volts
t_{rr}	Reverse Recovery Time ($I_S = -I_D [Cont.]$, $dI_S/dt = 100A/\mu s$)	250	500	1000	ns
Q_{rr}	Reverse Recovery Charge ($I_S = -I_D [Cont.]$, $dI_S/dt = 100A/\mu s$)	2.5	5	10	μC

SAFE OPERATING AREA CHARACTERISTICS

Symbol	Characteristic	Test Conditions	MIN	TYP	MAX	UNIT
SOA1	Safe Operating Area	$V_{DS} = 0.4 V_{DSS}, I_{DS} = P_D / 0.4 V_{DSS}, t = 1 Sec.$	310			Watts
SOA2	Safe Operating Area	$I_{DS} = I_D [Cont.], V_{DS} = P_D / I_D [Cont.], t = 1 Sec.$	310			
I_{LM}	Inductive Current Clamped	APT1001RBNR	44			Amps
		APT1001R1BNR	42			

① Repetitive Rating: Pulse width limited by maximum junction temperature.

③ See MIL-STD-750 Method 3471

② Pulse Test: Pulse width < 380 μs , Duty Cycle < 2%

④ Starting $T_J = +25^\circ C$, $L = 20mH$, $R_G = 25\Omega$, Peak $I_L = 11A$

APT Reserves the right to change, without notice, the specifications and information contained herein.

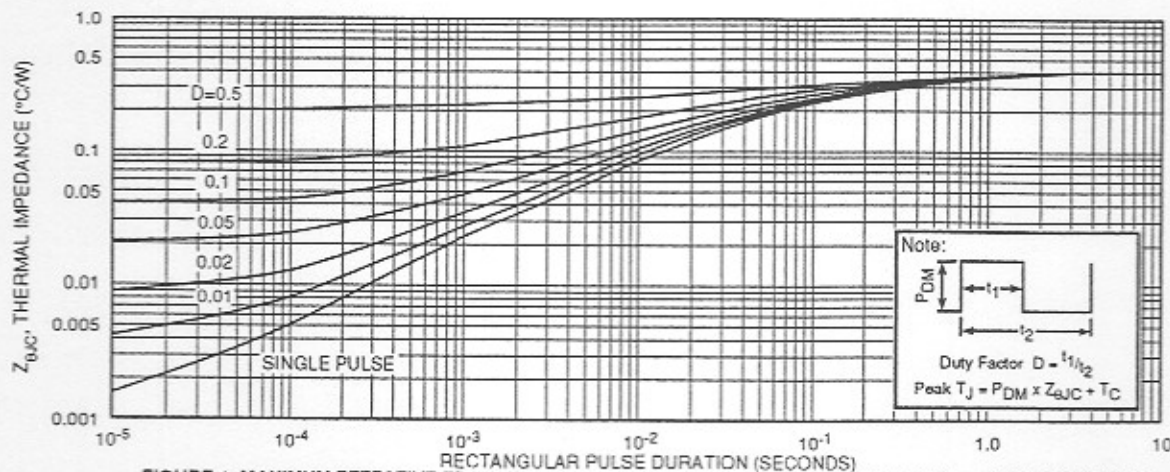

FIGURE 1, MAXIMUM EFFECTIVE TRANSIENT THERMAL IMPEDANCE, JUNCTION-TO-CASE vs PULSE DURATION

APT1001R/1001R1BNR

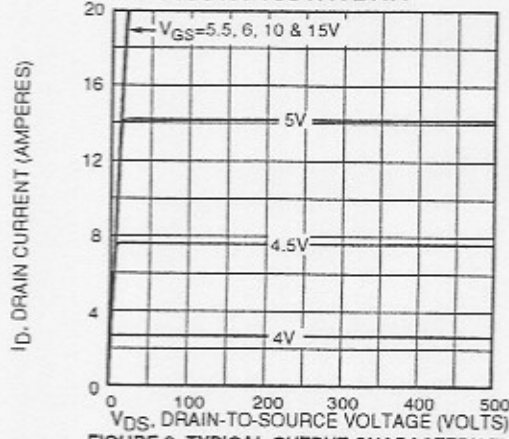

FIGURE 2, TYPICAL OUTPUT CHARACTERISTICS

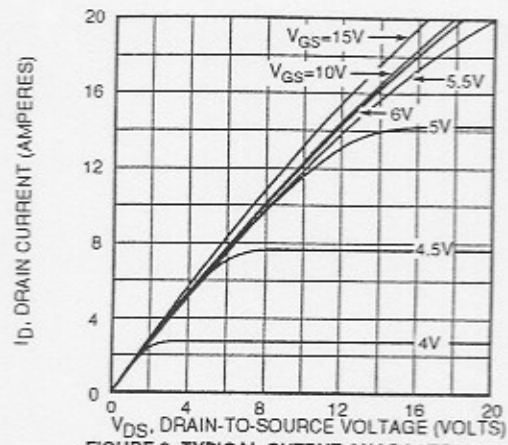

FIGURE 3, TYPICAL OUTPUT CHARACTERISTICS

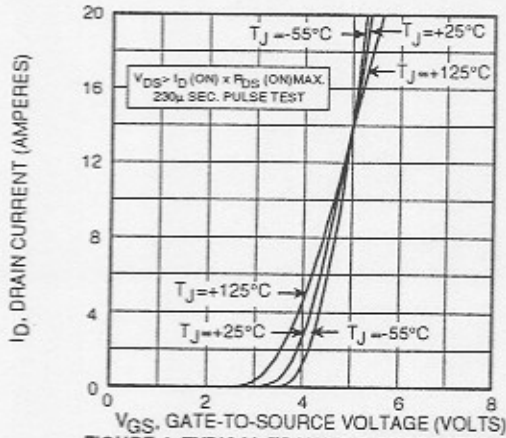

FIGURE 4, TYPICAL TRANSFER CHARACTERISTICS

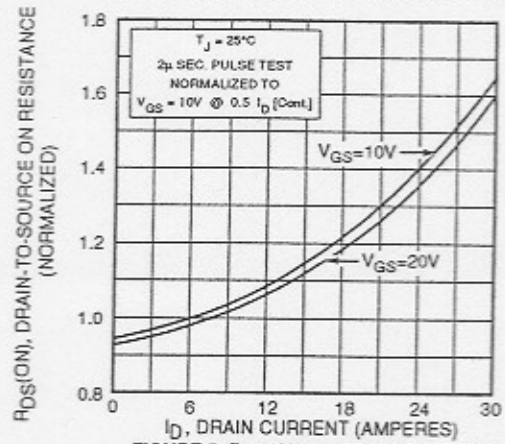

FIGURE 5, $R_{DS(ON)}$ vs DRAIN CURRENT

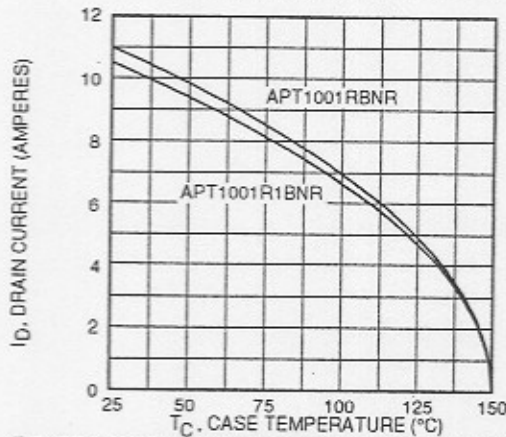

FIGURE 6, MAXIMUM DRAIN CURRENT vs CASE TEMPERATURE

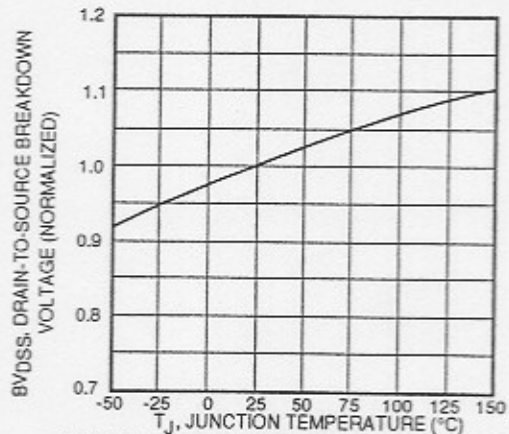

FIGURE 7, BREAKDOWN VOLTAGE vs TEMPERATURE

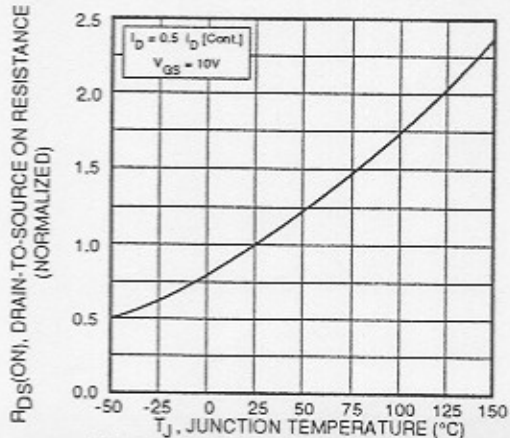

FIGURE 8, ON-RESISTANCE vs. TEMPERATURE

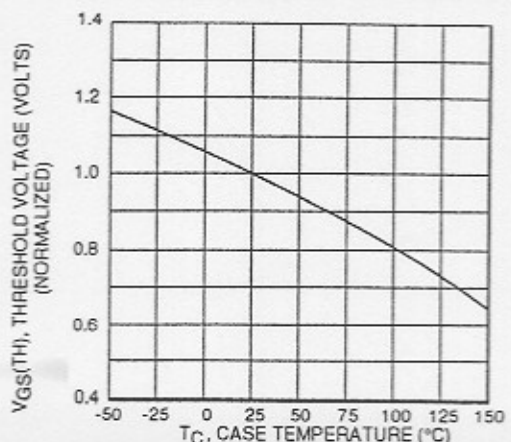

FIGURE 9, THRESHOLD VOLTAGE vs TEMPERATURE

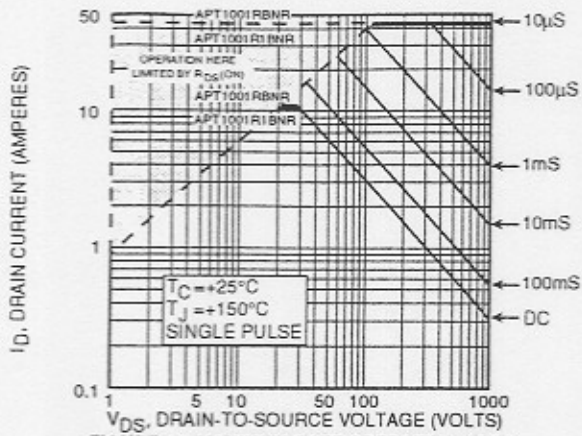

FIGURE 10, MAXIMUM SAFE OPERATING AREA

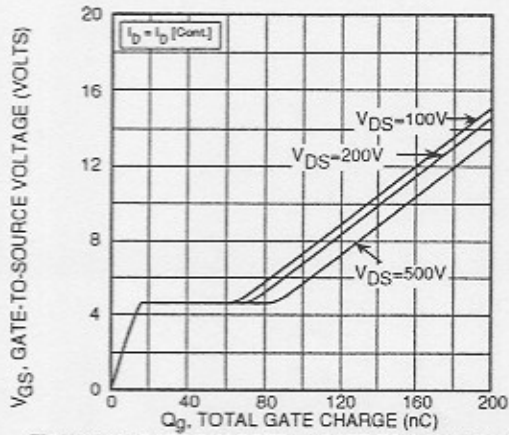

FIGURE 12, GATE CHARGES vs GATE-TO-SOURCE VOLTAGE

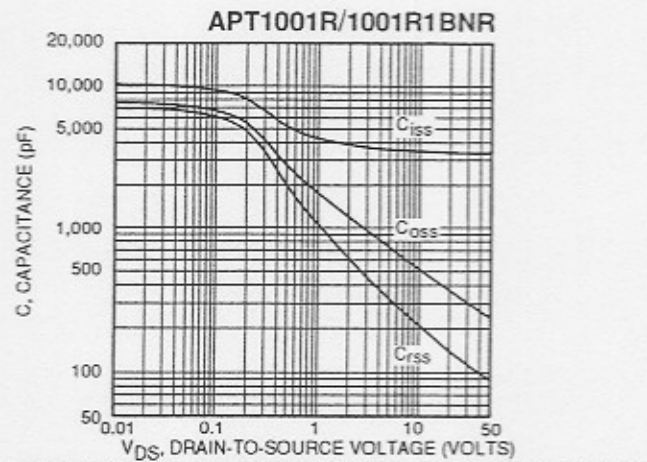

FIGURE 11, TYPICAL CAPACITANCE vs DRAIN-TO-SOURCE VOLTAGE

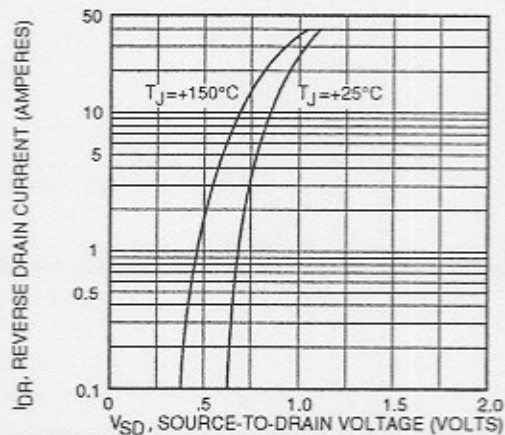
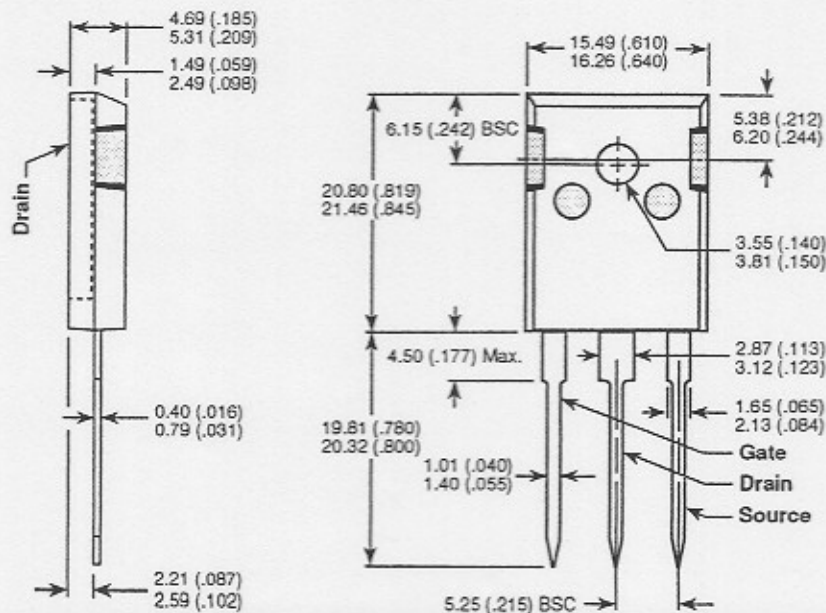

FIGURE 13, TYPICAL SOURCE-DRAIN DIODE FORWARD VOLTAGE

TO-247AD Package Outline



Dimensions in Millimeters and (Inches)