

8958

VOICE COIL MOTOR DRIVER

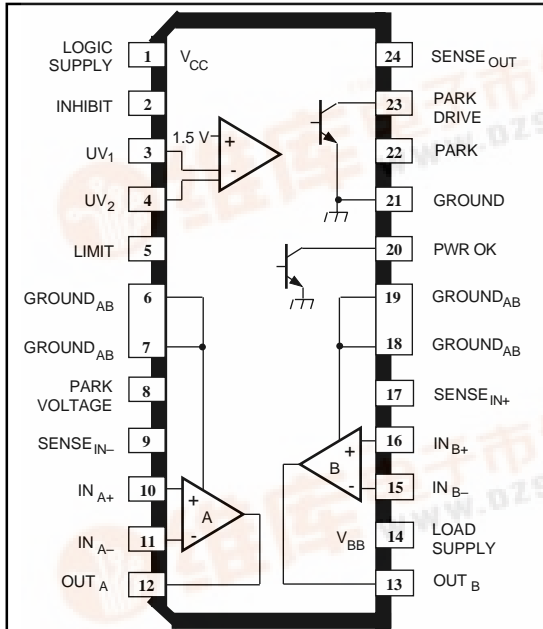

Dwg. PP-054

ABSOLUTE MAXIMUM RATINGS at $T_A = 25^\circ\text{C}$

Supply Voltages, V_{BB} and V_{CC}	16 V
Output Current, I_{OUT}	± 1.0 A
Park Drive Output Current, I_{PARK}	
Continuous	250 mA
Peak	1.0 A
Amplifier Input Voltage Range,	
V_{IN}	-2.0 V to V_{CC}
Sense Input Voltage Range,	
$V_{SENSE\ IN}$	-0.3 V to V_{CC}
Comparator and Digital Inputs,	
V_{IN}	-0.3 V to 10 V
I_{IN}	± 10 mA
Power OK Output, V_{CEX}	20 V
I_C	30 mA
Output Clamp Diode Current,	
I_F (pulsed)	1.0 A
Package Power Dissipation, P_D ..	See Graph
Operating Temperature Range,	
T_A	0°C to $+70^\circ\text{C}$
Junction Temperature, T_J	150°C^*
Storage Temperature Range,	
T_S	-55°C to $+150^\circ\text{C}$

* Fault conditions that produce excessive junction temperature will activate device thermal shutdown circuitry. These conditions can be tolerated but should be avoided.

Providing control and drive of the voice coil motor used for head positioning in disk drive applications, the A8958CLB is a full-bridge driver which can be configured so that its output current is a direct function of an externally applied control voltage or current. This linear current control function is supplemented by additional circuitry to protect the heads and the data disk during system failure or normal system shutdown.

The two ± 800 mA driver outputs provide very-low saturation voltage drops and precise current control utilizing a single current-sensing resistor connected in series with the load. Under-voltage lockout disables the system in a controlled sequence if a fault condition occurs.

When activated by the under-voltage comparator, or a park command, the output power drivers change from a controlled current to a user-determined constant park voltage. Other features include a power ok flag, a limit input to force the outputs to their maximum level in either polarity, an over-riding output disable to shut down both power amplifiers and reduce quiescent supply current, and internal thermal shutdown which disables the load (but still allowing the head to be parked) in the event of excessive junction temperatures. The load is re-enabled when the junction temperature returns to a safe level.

The A8958CLB is supplied in a 24-lead power SOIC for surface-mount applications. The copper batwing construction provides for maximum package power dissipation in a minimum package size. It is rated for continuous operation over the temperature range of 0°C to $+70^\circ\text{C}$.

FEATURES

- Controlled-Velocity Head Parking
- Zero Deadband
- High Transconductance Bandwidth
- User-Adjustable Transconductance Gain
- ± 800 mA Load Current
- Dual Under-Voltage Monitors with Flag and User-Selectable Trip Points
- Internal Thermal Shutdown Circuitry
- Replaces UC3175

Always order by complete part number, e.g., **A8958CLB**.

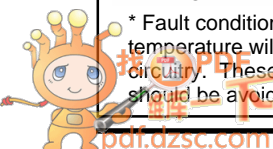

8958 VOICE COIL MOTOR DRIVER

FUNCTIONAL BLOCK DIAGRAM

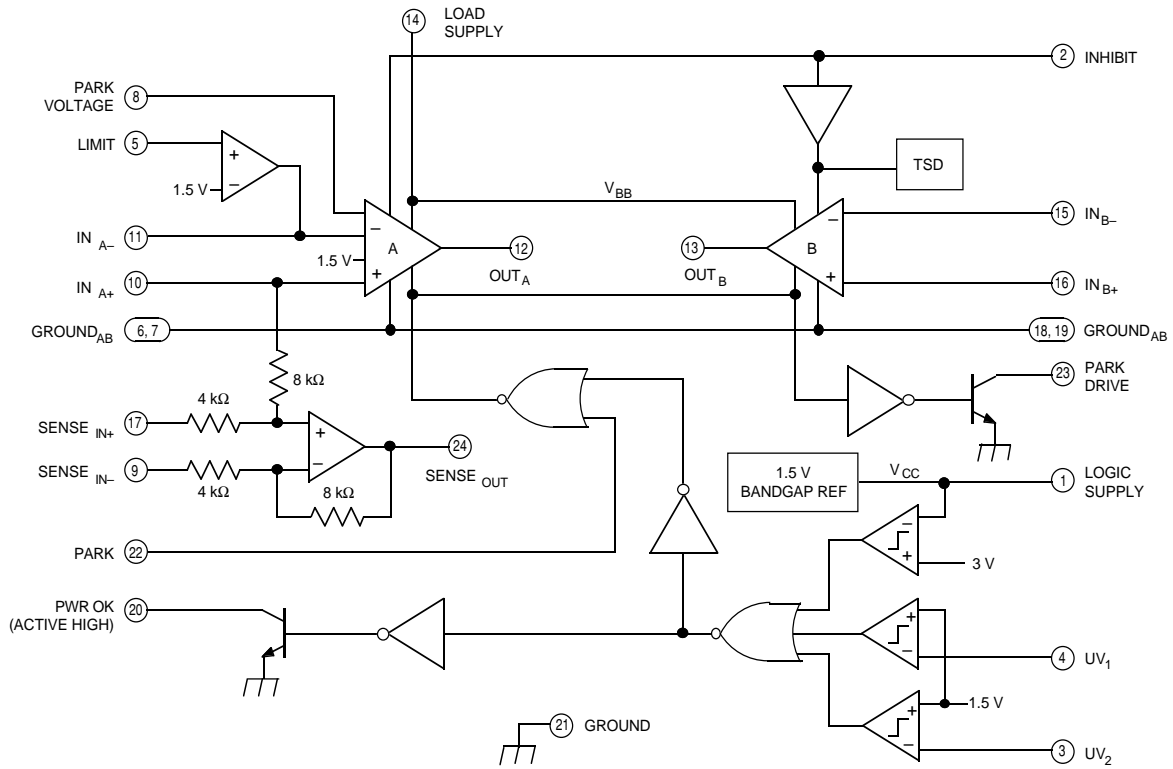

Dwg. FP-020C

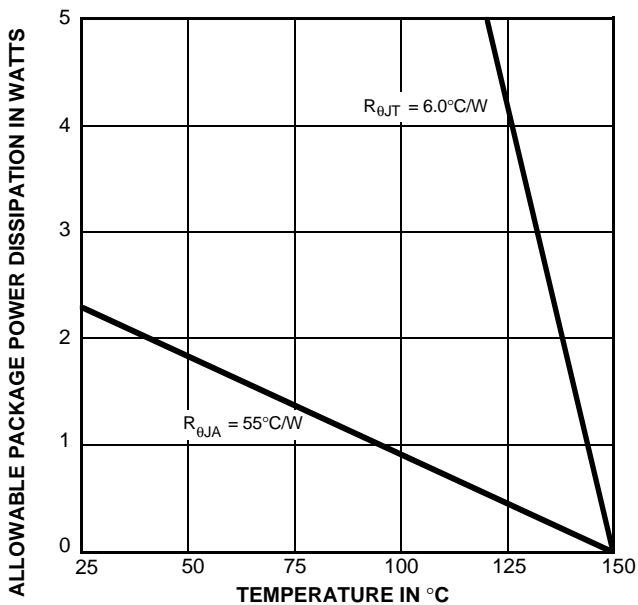

Dwg. GP-033A

8958
VOICE COIL
MOTOR DRIVER

ELECTRICAL CHARACTERISTICS at $T_A = +25^\circ\text{C}$, $V_{CC} = V_{BB} = 12\text{ V}$

Characteristic	Symbol	Test Conditions	Limits			
			Min.	Typ.	Max.	Units
Logic Supply Voltage Range	V_{CC}	Operating	8.0	12	16	V
Logic Supply UV Threshold	V_{CC}	High-to-low transition	—	2.8	3.0	V
Logic Supply UV Hysteresis	ΔV_{CC}		—	200	—	mV
Supply Current	I_{BB}	$V_{OUT} = 6\text{ V}$, no load	—	2.0	—	mA
	I_{CC}		—	23	—	mA
Inhibited Supply Current	—	$I_{BB} + I_{CC}$, $V_2 \geq 1.7\text{ V}$	—	3.0	8.0	mA
Thermal Shutdown Temp.	T_J		—	165	—	$^\circ\text{C}$
Thermal Shutdown Hysteresis	ΔT_J		—	8.0	—	$^\circ\text{C}$

Output Power Drivers

Output Saturation Voltage	V_{SAT}	$I_{OUT} = 250\text{ mA}$	—	250	—	mV
		$I_{OUT} = 800\text{ mA}$	—	450	—	mV
		$I_{OUT} = -250\text{ mA}$	—	750	—	mV
		$I_{OUT} = -800\text{ mA}$	—	950	—	mV
Total Saturation Voltage (Source + Sink)	V_{SAT}	$I_{LOAD} = 250\text{ mA}$	—	1.0	1.4	V
		$I_{LOAD} = 800\text{ mA}$	—	1.4	2.0	V
Input Offset Voltage	V_{IO}	$V_{CM} = 6\text{ V}$	—	5.0	8.0	mV
Input Offset Drift	ΔV_{IO}		—	—	25	$\mu\text{V}/^\circ\text{C}$
Input Bias Current	I_{IN}	Except IN_{A+} , $V_{CM} = 6\text{ V}$	—	-150	-500	nA
		IN_{A+} to $SENSE_{IN+} = 12\text{ k}\Omega$, $T_J = 25^\circ\text{C}$	69	84	105	$\mu\text{A}/\text{V}$
Input Offset Current	I_{IO}	IN_B only, $V_{CM} = 6\text{ V}$	—	—	200	nA
Differential Sense Input Current	I_{ID}	$I_{OUT} = 5\text{ mA}$	—	± 300	—	μA
		$I_{OUT} = 500\text{ mA}$	—	3.0	—	mA
Large Signal Gain	A_{VS}	$V_{OUT} = 2\text{ V to } 10\text{ V}$, $I_{OUT} = \pm 500\text{ mA}$	1.5	5.0	—	V/mV
Slew Rate	SR		—	4.0	—	V/ μs
Unity Gain Bandwidth	BW	Amplifier A	0.5	1.0	1.7	MHz
		Amplifier B	0.5	2.0	2.2	MHz
Common-Mode Rejection	k_{CMR}	$V_{CM} = 1\text{ V to } 10\text{ V}$	70	90	—	dB
Clamp Diode Forward Voltage	V_F	$I_F = 800\text{ mA}$, $V_2 \geq 1.7\text{ V}$	—	1.0	1.2	V
High-Side Current Limit	I_{OUT}	$T_J = 25^\circ\text{C}$	—	1.0	1.2	A
Power Supply Rejection	k_{SVR}	$V_{CC} = 4\text{ V to } 15\text{ V}$, $V_{CM} = 1.5\text{ V}$	70	90	—	dB

Negative current is defined as coming out of (sourcing) the specified device terminal.
Typical Data is for design information only.

Continued next page...

8958

VOICE COIL MOTOR DRIVER

ELECTRICAL CHARACTERISTICS (continued)

Characteristic	Symbol	Test Conditions	Limits			
			Min.	Typ.	Max.	Units
Current Sense Amplifier						
Input Offset Voltage	V_{IO}	$V_{CM} = 6\text{ V}$	—	—	2.0	mV
Input Offset Drift	ΔV_{IO}	$V_{CM} = 0\text{ V to }12\text{ V}$	—	—	3000	$\mu\text{V/V}$
			—	—	8.0	$\mu\text{V}/^\circ\text{C}$
Voltage Gain	A_{VS}	$V_{ID} = -1\text{ V to }+1\text{ V}, V_{CM} = 6\text{ V}$	1.95	2.00	2.05	—
Output Saturation Voltage	V_{SAT}	$V_{OUT}, I_{OUT(SINK)} = 1.5\text{ mA}$	—	300	500	mV
		$V_{CC} - V_{OUT}, I_{OUT(SOURCE)} = -1.5\text{ mA}$	—	400	700	mV
Park Function						
PARK DRIVE Leakage Current	I_{CEX}	$V_{CEX} = 20\text{ V}$	—	—	100	μA
PARK DRIVE Saturation Voltage	$V_{CE(SAT)}$	$I_C = 200\text{ mA}$	—	300	500	mV
PARK Input Threshold	V_{PARK}		0.7	1.1	1.7	V
PARK Input Current	I_{PARK}	$V_{PARK} = 1.7\text{ V}$	—	—	100	μA
PARK VOLTAGE Input Current	$I_{PARK V}$		—	-150	-500	nA
Under-Voltage Protection						
UV Threshold	V_{UV}	Low-to-High Trans., Other Input = 6 V	1.48	1.50	1.52	V
UV Threshold Hysteresis	ΔV_{UV}		15	25	45	mV
UV Input Current	I_{UV}	$V_{UV} = 1\text{ V}$	—	-0.5	-1.5	μA
PWR OK Saturation Voltage	$V_{CE(SAT)}$	$I_C = 5\text{ mA}$	—	—	450	mV
PWR OK Leakage Current	I_{CEX}	$V_{CEX} = 20\text{ V}$	—	—	5.0	μA
Auxiliary Functions						
LIMIT Input Voltage	$V_{LIMIT(L)}$	OUT _A forced Low	0.7	0.8	—	V
	$V_{LIMIT(H)}$	OUT _A forced High	—	2.2	2.3	V
	V_{LIMIT}	Limit inactive	1.2	—	1.8	V
		Open circuit	1.45	1.50	1.55	V
LIMIT Input Resistance	R_{LIMIT}	$V_{LIMIT} = 1.2\text{ V to }1.8\text{ V}$	—	10	—	k Ω
INHIBIT Input Threshold	V_2		0.7	1.1	1.7	V
INHIBIT Input Current	I_2	$V_2 = 1.7\text{ V}$	—	—	200	μA

Negative current is defined as coming out of (sourcing) the specified device terminal.

Typical Data is for design information only.

8958
VOICE COIL
MOTOR DRIVER

TERMINAL FUNCTIONS

Term.	Terminal Name	Function
1	LOGIC SUPPLY	V_{CC} ; logic supply voltage.
2	INHIBIT	An active-high logic input that inhibits the output stages without initiating a park.
3 & 4	UV_1 and UV_2	Under-voltage detection inputs. If not used, these terminals must be connected to the logic supply (V_{CC}).
5	LIMIT	A tri-state input that forces the output of amplifier A into saturation in either direction, or allows normal linear operation.
6 & 7	$GROUND_{AB}$	Power amplifiers' ground and thermal heat sink.
8	PARK VOLTAGE	Auxiliary inverting input to power amplifier A.
9	$SENSE_{IN-}$	Inverting input to current sense error amplifier.
10	IN_{A+}	Non-inverting input to power amplifier A.
11	IN_{A-}	Inverting input to power amplifier A.
12	OUT_A	Power amplifier A output to voice coil motor.
13	OUT_B	Power amplifier B output to voice coil motor.
14	LOAD SUPPLY	V_{BB} ; load supply voltage.
15	IN_{B-}	Inverting input to power amplifier B.
16	IN_{B+}	Non-inverting input to power amplifier B.
17	$SENSE_{IN+}$	Non-inverting input to current sense error amplifier.
18 & 19	$GROUND_{AB}$	Power amplifiers' ground and thermal heat sink.
20	PWR OK	A logic low at this output indicates an under-voltage condition.
21	GROUND	Circuit reference.
22	PARK	An active-high logic input that activates the park function.
23	PARK DRIVE	Power transistor for retract current control on power down or park command.
24	$SENSE_{OUT}$	Output of current sense error amplifier.

8958 VOICE COIL MOTOR DRIVER

CURRENT SENSING

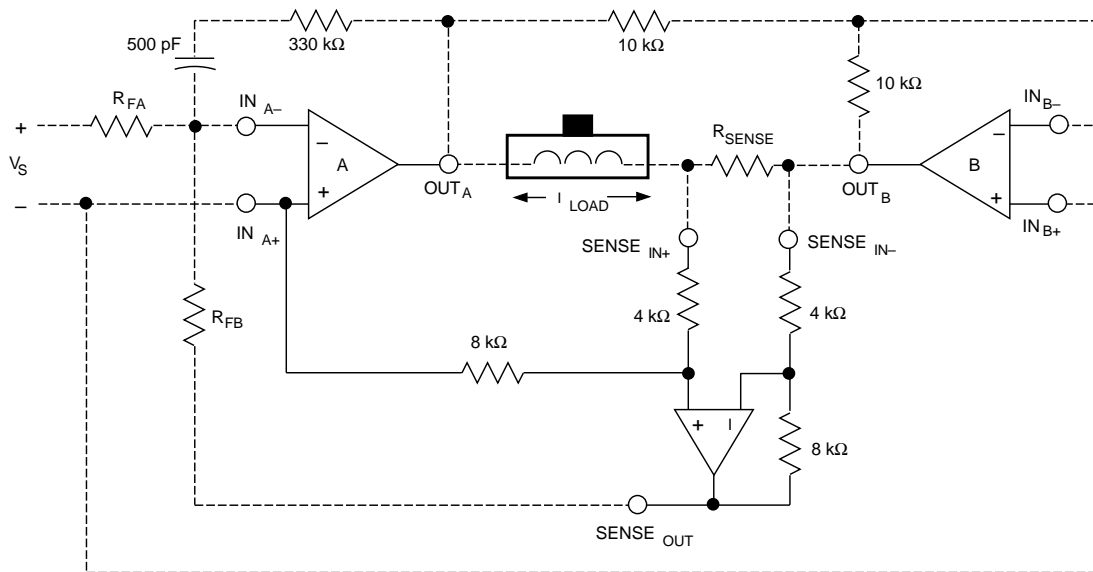

Dwg. EP-034

PARKING FUNCTION

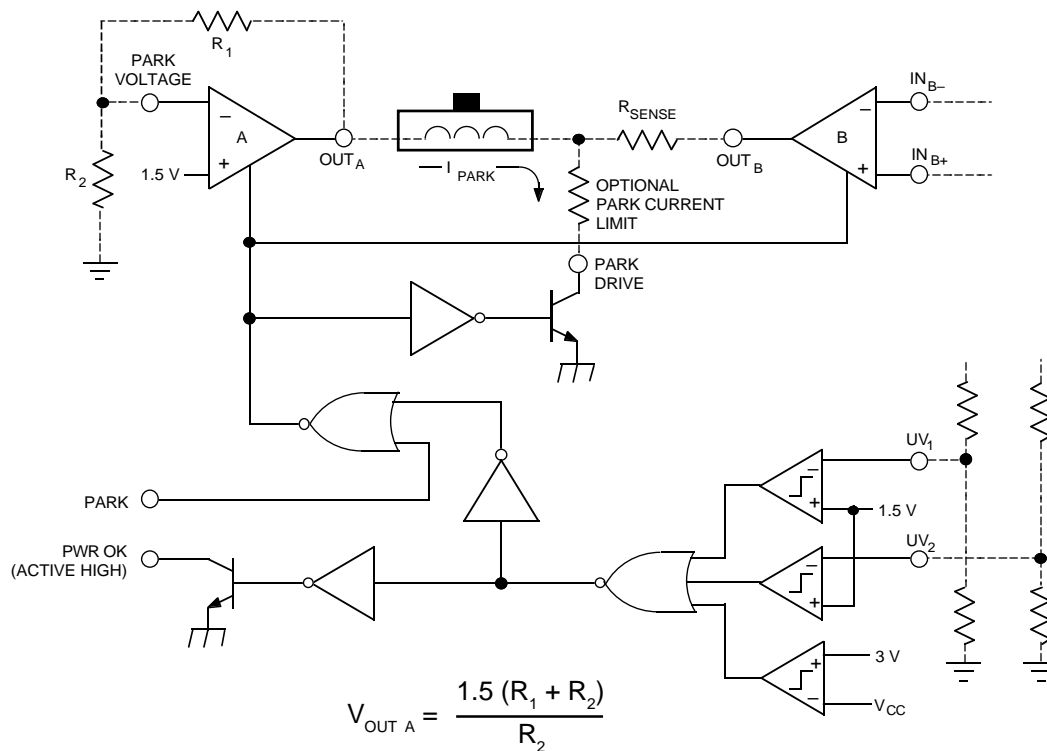

Dwg. EP-039

8958 VOICE COIL MOTOR DRIVER

Dimensions in Inches (for reference only)

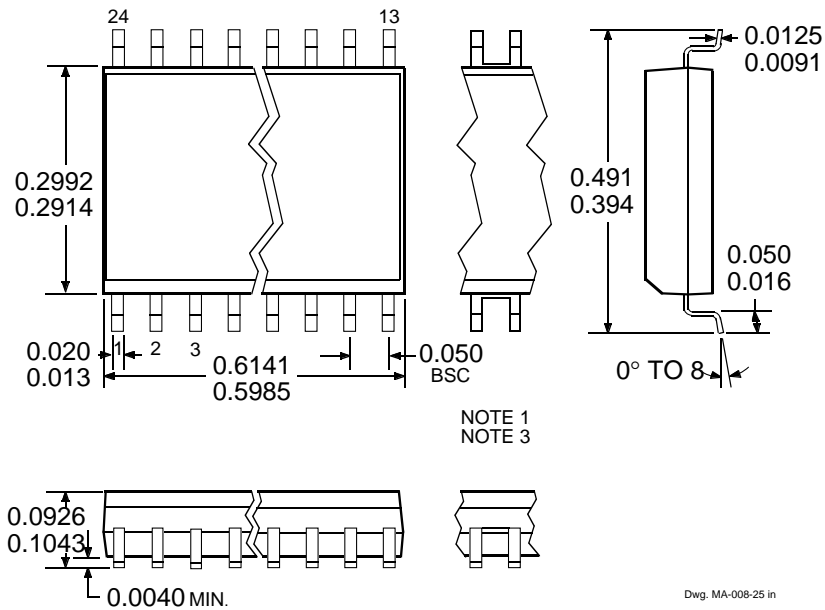

Dimensions in Millimeters (controlling dimensions)

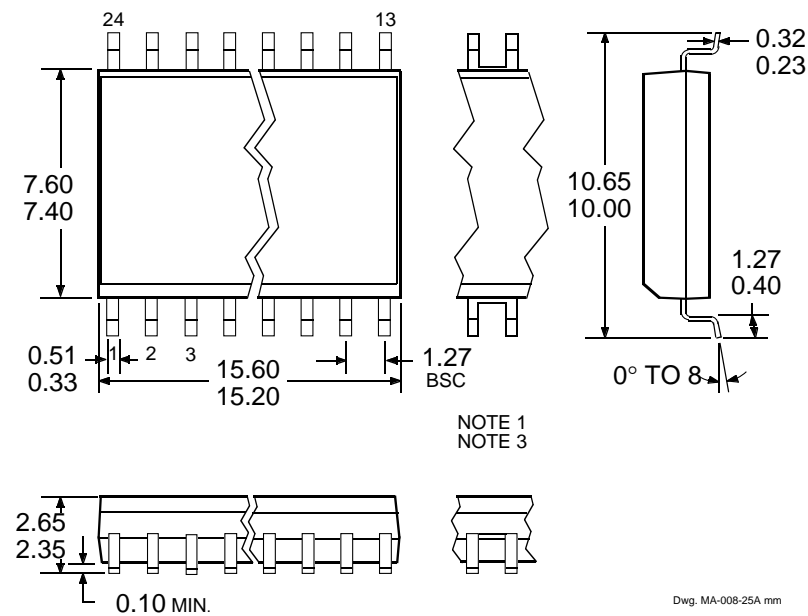

- NOTES:
1. Webbed lead frame. Leads 6, 7, 18, and 19 are internally one piece.
 2. Lead spacing tolerance is non-cumulative.
 3. Exact body and lead configuration at vendor's option within limits shown.

8958
VOICE COIL
MOTOR DRIVER

The products described here are manufactured under one or more U.S. patents or U.S. patents pending.

Allegro MicroSystems, Inc. reserves the right to make, from time to time, such departures from the detail specifications as may be required to permit improvements in the performance, reliability, or manufacturability of its products. Before placing an order, the user is cautioned to verify that the information being relied upon is current.

Allegro products are not authorized for use as critical components in life-support devices or systems without express written approval.

The information included herein is believed to be accurate and reliable. However, Allegro MicroSystems, Inc. assumes no responsibility for its use; nor for any infringement of patents or other rights of third parties which may result from its use.