

PRELIMINARY

Notice : This is not a final specification
Some parametric limits are subject to change.

MITSUBISHI SEMICONDUCTOR <GaAs MMIC>

MGFC5212

K-Band 2-Stage Power Amplifier

DESCRIPTION

The MGFC5212 is a GaAs MMIC chip especially designed for 24.5 ~ 26.5 GHz band High Power Amplifier (HPA) .

FEATURES

- RF frequency : 24.5 to 26.5 GHz
- Linear gain : 13 dB
- P1dB : 23 dBm
- DC power : Vd = 5 V, Id1 + Id2 = 270 mA

BLOCK DIAGRAM

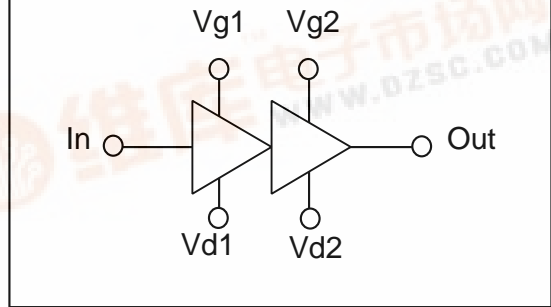

ABSOLUTE MAXIMUM RATINGS (Ta = 25 °C)

Symbol	Parameter	Ratings	Units
Vd1, Vd2	Drain supply voltage	6	V
Vg1, Vg2	Gate supply voltage	-3 ~ 0.5	V
Id1	Drain current 1	120	mA
Id2	Drain current 2	240	mA
Pin	RF input power	16	dBm
Ta	Backside ambient temp.	-20 ~ +70	°C
Tstg	Storage temp.	-65 ~ +175	°C
Tmax	Maximum assembly temp.	+300	°C

ELECTRICAL CHARACTERISTICS (Ta = 25 °C)

Symbol	Parameter	Conditions	Limits			Units
			Min.	Typ.	Max.	
Gain	Gain	Vd = 5 V Id1 = 90 mA Id2 = 180 mA (RF off)	13.0			dB
VSWR in	Input VSWR				2.2	-
VSWR out	Output VSWR				2.2	-
P1dB	Output power at 1 dB compression point	f = 24.5, 26.5 GHz Single tone	23.0			dBm
IM3	Inter modulation level	f = 24.5, 26.5 GHz Two tone(10MHz off) Pout = 20 dBm	(22.0)			dBc

PRELIMINARY

Notice : This is not a final specification
Some parametric limits are subject to change.

MITSUBISHI SEMICONDUCTOR <GaAs MMIC>

MGFC5212

K-Band 2-Stage Power Amplifier

DIE SIZE AND BOND PAD LOCATION(UNIT : μM)

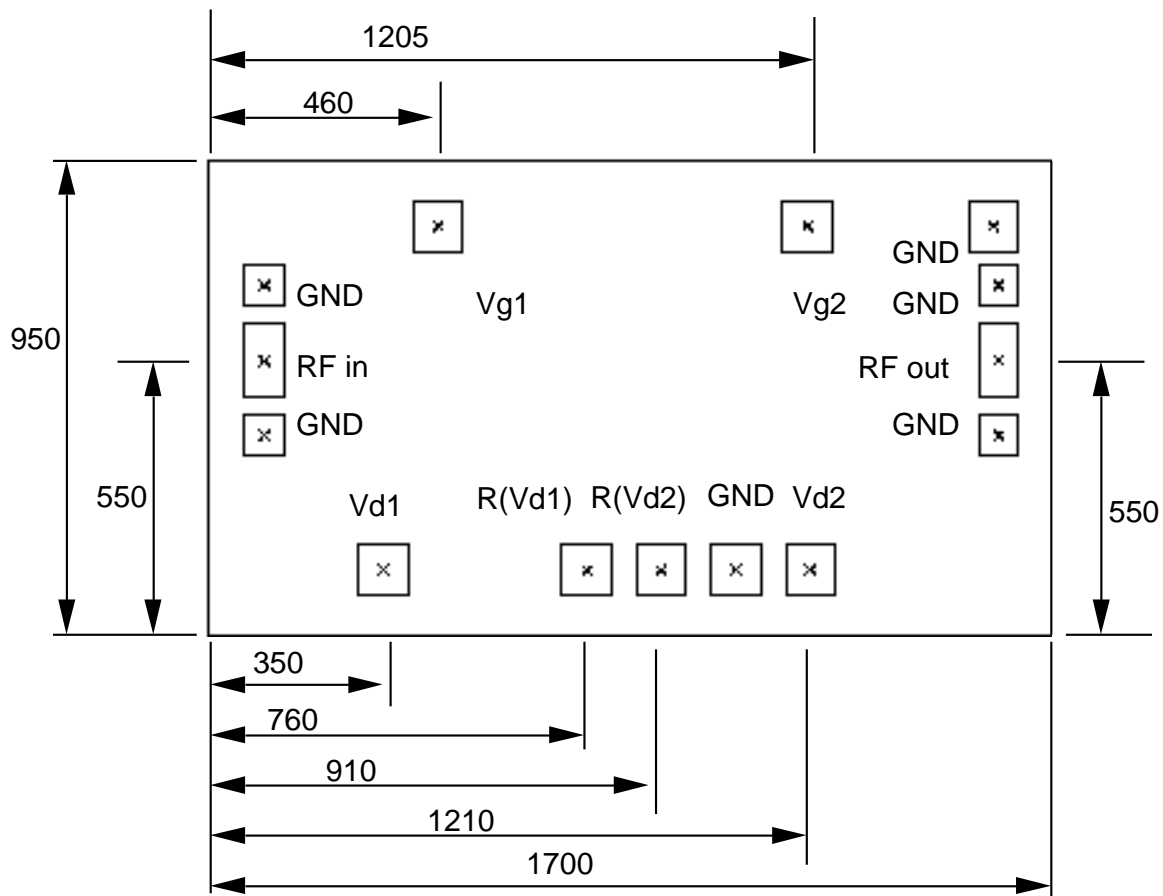

X Dimension 1.70 mm
Y Dimension 0.95 mm

PRELIMINARY

Notice : This is not a final specification
Some parametric limits are subject to change.

MITSUBISHI SEMICONDUCTOR <GaAs MMIC>

MGFC5212

K-Band 2-Stage Power Amplifier

TYPICAL CHARACTERISTICS

Small Signal Performances

($V_d = 5\text{ V}$, $I_{d1} = 90\text{ mA}$, $I_{d2} = 180\text{ mA}$, $T_a = 25\text{ }^\circ\text{C}$)

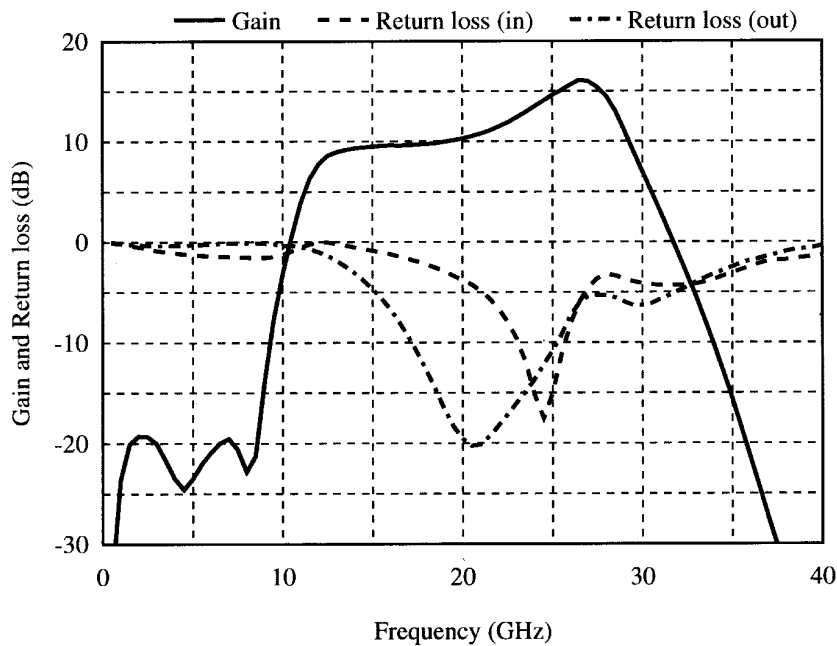

Output Power Performances

($V_d = 5\text{ V}$, $I_{d1} = 90\text{ mA}$, $I_{d2} = 180\text{ mA}$, $T_a = 25\text{ }^\circ\text{C}$)

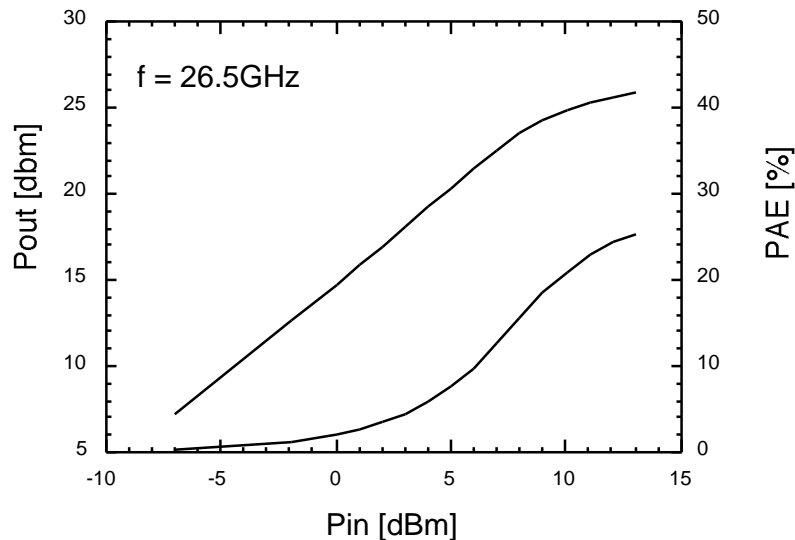

PRELIMINARY

Notice : This is not a final specification
Some parametric limits are subject to change.

MITSUBISHI SEMICONDUCTOR <GaAs MMIC>

MGFC5212

K-Band 2-Stage Power Amplifier

AN EXAMPLE OF TEST CIRCUIT

